

INSTALLATION INSTRUCTIONS

PL-250 Series Paver Light

Architectural Lighting For Interlocking Concrete Pavement



Components Required For A Complete Fixture:

- | | |
|-------------------------|----------------------------|
| (Poly-bagged) | (Sold Separately) |
| 1 Lamp Support Assembly | 1 PL250 Series Lamp Module |
| 1 Power Tap Connector | |
| 1 Wire Harness | |

Paver Coring

Pavers must be cored prior to installation. Pavers should be cored by using only a professional core drill, or the optional Field Installation Kit sold separately. Use only a standard 2 1/2" (6.35 cm) diameter diamond-tipped core bit intended for this purpose. **DO NOT** use a carbide-tipped bit! The bore (#1) should have a neat, clean appearance, especially at the top. It is highly recommended to use the Adjustable Coring Template accessory for accurate placement when drilling by hand. For coring services and equipment see your participating Evening Star Dealer.

Assembly

1. Remove the protective tape from the underside of the Lamp Module (#2) exposing the socket and anti-corrosive compound.
NOTE: Do not wipe off. This will ensure a watertight connection.
2. Plug the wire harness into the Lamp Module (#3). Feed the remaining cable out through the base until it stops (#4).
NOTE: 6 inches of wire will remain inside the base.
3. Align the locking ears on the Lamp Module with the top of the base. Twist the module 1/4 turn (90°) clockwise, locking it in place as shown by the arrow (#5).
NOTE: Do not use excessive force or rotate more than 1/4 turn (90°).
4. Repeat steps 1 to 3 until all fixtures have been assembled.

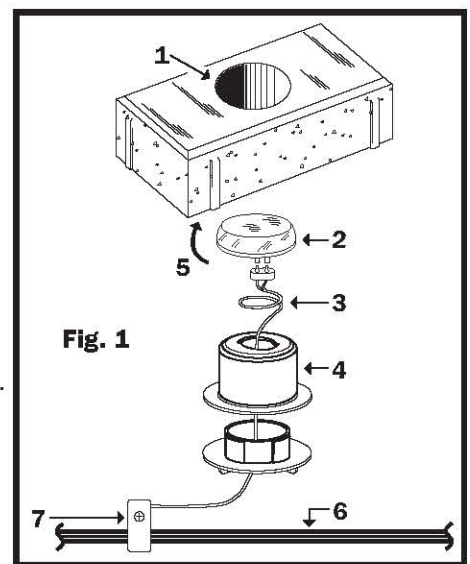

Placement

WARNING: Risk of Electric Shock. Install all luminaries 10 feet (3.05 m) or more from a pool, spa, or fountain.

1. Select the correct power unit by adding up the total number of fixtures and multiplying by 4. The total system wattage must not exceed your power unit's rated output capacity. Fixtures are only to be used with a UL listed low voltage landscape lighting power unit rated up to 300 watts, 25 amps and 15 volts maximum output per secondary.
NOTE: To obtain maximum lamp performance, choose a power unit with ratings that are equal to or slightly greater than the total system wattage.
2. We recommend using 12/2 landscape lighting cable (#6) when connecting fixtures using the Power Tap Connector (#7). Power Tap Connectors are double-sided and will accommodate either 12/2 single circuit, or 10/3 dual circuit cable, which offers greater design flexibility for advanced installers (Fig. 2).
3. Begin by connecting one end of the supply cable to the power unit. Lay the remaining cable on the sand setting bed, forming a continuous loop around your project just prior to placing your pavers. Lay the cable flat, routing it in close proximity to the desired fixture locations. Do not install any fixtures at this time.
4. Be sure to observe the correct polarity when splicing cables, or attaching the other cable end back to the power unit by noting the ridge or markings on one side of the cable. If more cable is needed, contact your point of purchase.
5. Complete the paver installation. **DO NOT** tamp at this time.
NOTE: The cable should be protected by routing in close proximity to a fixture, or building structure such as a house or deck, and is intended for shallow burial. Do not bury cable deeper than 6 inches (15.24 cm) below the surface. Avoid laying the cable directly under a fixture. When splicing cable, it is recommended to use UL listed wire nuts suited for direct burial.

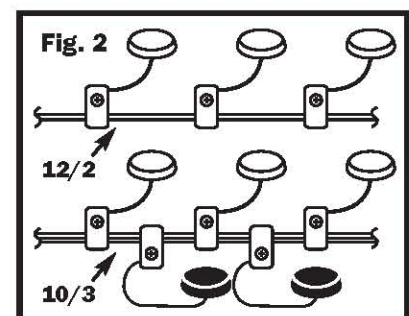

Continued On Back Side

Spacing And Installation

1. To calculate even spacing, such as with a patio, begin by measuring the length and width (Fig. 3).
EXAMPLE: L=18, W=12.
2. Set your desired spacing for the fixtures.
TIP: A 6 to 7 foot spacing between fixtures (1.82 to 2.13 M) will offer an aesthetically pleasing effect.
3. Assuming you will place a fixture at each corner, divide your measurements by the total number of fixtures desired and subtract 1. The sum of your calculation will be the center-to-center spacing.
EXAMPLE: For a patio 18 feet long with 4 fixtures, $18 \div (4-1) = 6$ foot spacing.
4. Mark your pavers with chalk where each fixture is to be placed. Using a suitable paver extractor, remove enough pavers so you can easily access the circuit cable (Fig. 4).

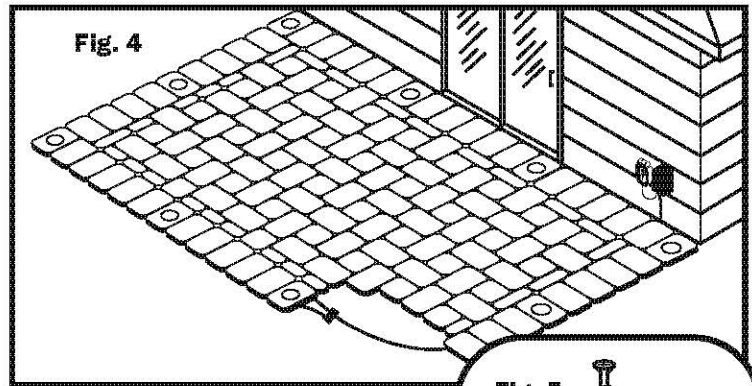
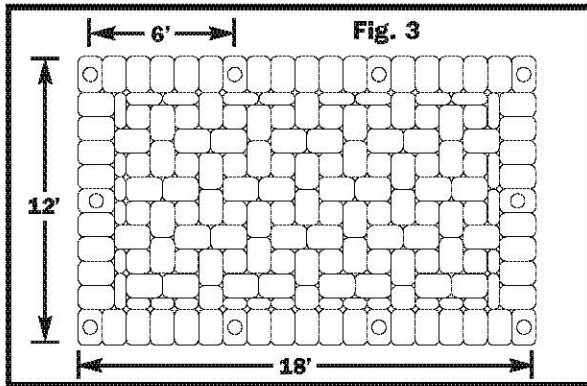
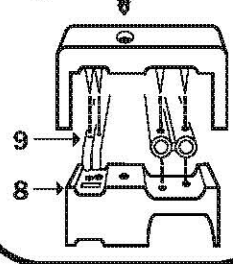

Fig. 5



Connecting The Lights

1. Turn the power unit on.
NOTE: It is highly recommended to install fixtures while the power unit is turned on.
2. Remove the Philips screw on the Power Tap Connector, and separate the two halves (Fig. 5).
3. Inspect the connector to ensure the prongs are straight.
NOTE: If the prongs are bent, straighten with pliers.
4. Insert the end of the wire harness into the small rectangular hole on the base of the connector (#8), then bend the wire over, pressing it firmly into the small groove. The wire will exit out only one side of the tap connector.
5. Place the supply cable in the large groove, pressing it firmly into place.
6. Carefully align the top section over the bottom section, pressing the two halves together.
NOTE: The prongs must pierce the exact center of each cable (#9). Each fixture will light as the prongs pierce the supply cable.
7. Re-install the Philips head screw. If a fixture needs to be moved, simply remove the connector and relocate it.
NOTE: Don't over tighten the screw, or use pliers. Do not bury the connector deeper than 3 inches (7.62 cm).
8. Dig a small pocket in the sand to provide ample room for the Power Tap Connector. Insert the fixture into the paver and place in desired location. Re-install any remaining pavers and set by using a rubber mallet or hand tamper. Finish by sweeping regular sand over the Lamp Module and pavers.
NOTE: DO NOT use a plate compactor over the fixtures.
DO NOT use polymeric joint sand around the Lamp Modules or the paver they are in.

Care and Service

Evening Star Lamp Modules are completely sealed and maintenance-free. This lighting system is designed to last for many years under normal conditions. However, lamps eventually burn out and losing one can shorten the life of the others. Conditions beyond control (high input voltage, poor voltage regulation, etc.) will also affect lamp life. Therefore, it is important to promptly replace a burned out lamp. Care should be taken to never use any petroleum or detergent-based cleaning agents or solvents on, or around the lamp modules as this can soften or weaken plastic components. Additionally, you should avoid placing direct pressure on the lamp modules. Avoid mounting locations such as areas with loose stones, or prolonged exposure to vehicular traffic.